

OPERATION AND MAINTENANCE MODEL 1584 BLEED OR DRAIN VALVE

This bleed valve is designed to vent high pressure or condensate from charging lines, filters, separators and other volumes where pressure must be relieved to disconnect lines, tanks etc. It has an exclusive seal design that permits opening and closing thousands of times without loss of sealing ability. Light finger pressure is all that's required however over torquing should not damage the valve. It replaces our 1004 drain valve. It's design and size is the same as the 1004 valve but includes a side locking screw that prevents unintentional removal or loss of the screw.

SPECIFICATIONS

- Maximum rated press. 7000 PSI
- Materials seals Teflon
body aluminum
- Ports 1/4" MNPT
- Size 7/8" dia x 1.7" long

INSTALLATION

Use 3 or 4 turns of teflon tape pipe thread sealant. Avoid over torquing the pipe threads. Torque that can easily be applied with a 6 or 8 inch wrench is enough. Excessive torque can cause eventual cracking and leakage. These valves are NOT provided oxygen clean and should NOT be used in oxygen service as provided. Consult factory for details.

OPERATION:

These valves requires only a light finger torque to seal at pressures to 7000 PSI. Full flow is achieved by opening the bleed valve 1/2 to 3/4 turns. Avoid opening the valve more than this.

MAINTENANCE:

No routine maintenance is required. The valve should only be disassembled and reassembled by a qualified valve repair person following the drawing and notes herein. When replacing the teflon seat pry out the old seat with a pen knife. Drop the new seat in place. It will fit loosely until tightened the first time. When first tightening, hold the seat upward so it will not fall out of place. If time allows or a spare is available it is recommended the valve be returned to the factory for repairs.

PARTS LIST

ITEM	QTY	PART NO.	DISC.
1	1	1585	body
2	1	1586	screw
3	1	715	seat
4.	1	1584-4	locking screw 6-32 x 1/4 long w lock nut

NOTES:

1. Use Slick 50 grease on thread
2. To assemble or change seat, back off locking screw item 4, drop seat, item 3 into screw 2. Hold screw so seat is upward. Screw body 1 on to screw while continuing to hold in this position so seat won't fall out of place, retighten locking screw. Once tightened, seat will deform and be locked in place.

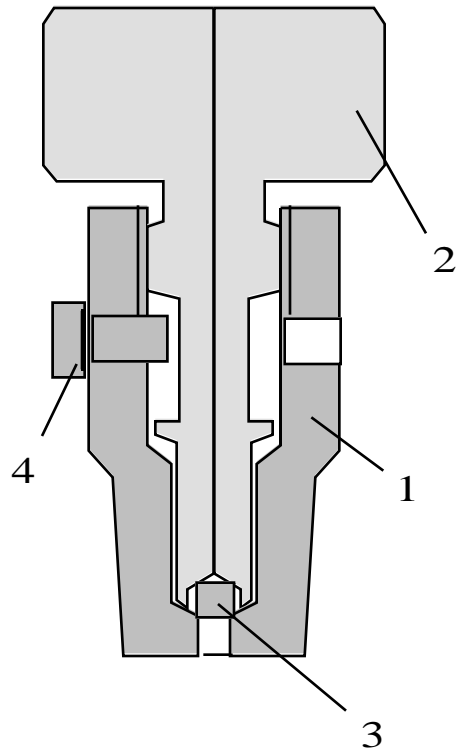

AQUA ENVIRONMENT CO. INC.,

PO Box 935, Stinson Beach, CA. , 94970, (415) 453 8157