

OPERATION AND MAINTENANCE MODEL 1091 HIGH FLOW TOGGLE VALVE

The Model 1091 toggle valve is an open or shut valve for air or gas lines up to 6000 PSI. In the normal or relaxed position the valve is shut and the lever extends straight out. When the lever is tipped in any direction the valve opens. A variety of levers can be connected to the 1/4"-20 thread. For example, using an eye bolt as shown, the valve could be operated by a lanyard. Alternately, a flat bar could be attached to the toggle with a short bolt. In many cases the valve eliminates the need for snap action switches, solenoids, and other complicated devices to open or shut a line based on mechanical action. One typical application is to open a cylinder charging line only when a protective door is shut. Here the door would push against the toggle to open the valve. A maximum of 30 inch pounds is required to actuate the valve at rated pressure. For example, a six inch lever would require five pounds to operate. A one inch thread section is provided on both ends permitting a variety of ways to mount the valve.

TECHNICAL SPECIFICATIONS

Maximum pressure, inlet	6000 PSI
differential	6000 PSI
outlet	6000 PSI
Ports, inlet	1/4" MNPT
outlet	1/4" FMPT
Flow coefficient (Cv)	0.8 (.23" orifice)
Materials, body	anodized aluminum
internals	brass & stainless
seals	Viton(TM) & KEL-F
Mod 816 lever actuating force	30 in-lbs at 6000

INSTALLATION

Use a suitable pipe thread sealant such as teflon tape on inlet and outlet threads. Do not over torque. Moderate torque applied with a 6 or 8 inch wrench is ample. Use ample teflon tape - 3 or 4 turns not 1 or 2 turns on pipe threads. The inlet is the male thread and outlet is the female thread at the side of the valve. The one inch thread at the top or bottom of the valve can be used to mount the valve through a one inch hole in a panel or mounting plate provided by the user. The actuating lever for the 816 can either be the eye bolt provided or any other lever extending in any direction as required by the application. The lever is mounted to the toggle (item 6 on the drawing) using the 1/4"-20 thread provided. The valve is NOT shipped oxygen clean and should NOT be used for oxygen service as provided. Consult the factory for details on oxygen service.

MAINTENANCE & REPAIR

CAUTION As with any regulator or valve, particulates or moisture can plug or freeze the internal filter or valve seat. This can occur when up-stream dryers are not changed or remain unused for long periods allowing corrosion materials to accumulate. In critical applications where it is important not to lose flow, a larger particulate filter should be used upstream. Also an orifice such as the Aqua model 796 should be used downstream. This reduces the tendency to freeze when moisture is present. Consult factory for details. The user should establish time intervals for changing the valve cartridge, filter and upstream dryers based on experience and service conditions. No representation is made herein as to time intervals as each use is unique. Back-up systems should be used in very critical applications since field maintenance is hard to insure. The poppet cartridge 895 is a factory assembled item and should be replaced if required and not disassembled unless absolutely necessary. Spare cartridges are available at a nominal cost and should be kept on hand if rapid repairs are required. Under severe conditions repacking of seal item 12 with Cristo lub per the drawing may periodically be required. IN ALL CASES THE UNIT CAN BE RETURNED TO THE FACTORY OR DEALER FOR REPAIR UNDER WARRANTY IF APPLICABLE OR AT A NOMINAL CHARGE. Maintenance or repairs should only be done by qualified personnel in a clean environment by following the drawings and parts lists herein.

**TOGGLE VALVE. HIGH FLOW, MODEL 1091
ASSEMBLY & DISASSEMBLY**

PARTS LIST

ITEM	QTY	PART NO.	DISCRIPTION
1	1	895	poppet cartridge assy
2	1	1070	body
3	1	1071	cap
4	1	815-1	stem
5	1	852	toggle cap
6	1	814	toggle
7	1	1091-7	1/4 x 20 x 4" eye bolt stl
8	1	1091-8	1/4 x 20 nut
9	1	1091-9	1" x 14, jam nut, plt stl
10	1	1091-10	2-028 viton, 90 duro seal
11	1	1091-11	2-020 viton, 90 duro seal
12	1	1091-12	2-006 viton, 90 duro seal
13		1091-13	REPAIR KIT - includes items 1,4,10,11,12
19	1	1638	guide

NOTES

1. Use Dow 111 grease on O rings and threads except seal 12. Fully pack this with Cristo lub MCG 121 or 11 or equivalent.
2. Use Slick 50 grease between (5) and(6)
3. Insure lever action does not put excessive force on piping connections
4. Technical bulletin - 1089
5. drawing 896 "poppet cartridge" is part of this drawing

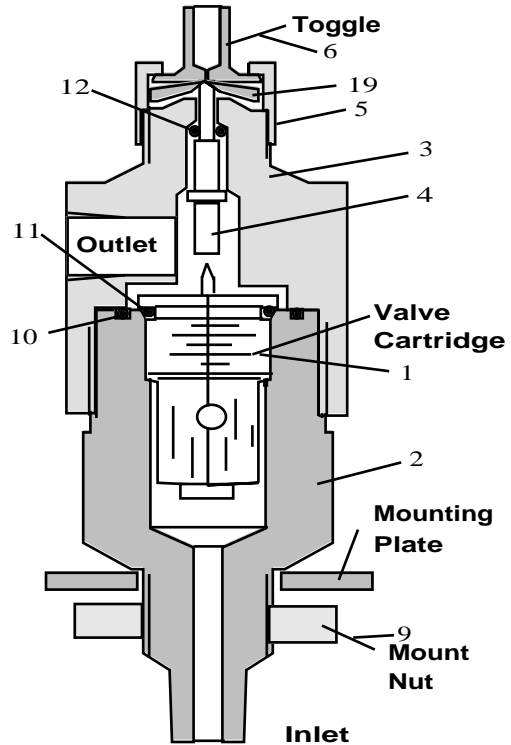

**Model 1091
Toggle Valve**

AQUA ENVIRONMENT INC.

3100 Kerner Blvd. Unit N, San Rafael, CA 94901 (415) 453 8157