

OPERATION AND MAINTENANCE

MODEL 684 CHECK VALVE

The model 684 check valve permits flow in one direction only thus eliminating the possibility of back flow. It is suitable for any noncorrosive gas or liquid flow. The simple reliable design uses O ring seals to insure bubble tight sealing even with very low back pressures.

SPECIFICATIONS

- Maximum rated press. 6000 PSI
- Maximum back press. 6000 PSI
- Opening press. 3 to 8 PSI
- Flow capacity Cv = 0.55 (.28" orifice)
- Materials
 - seals Viton
 - body aluminum
 - internals brass, stainless
- Ports
 - inlet 1/2" MNPT
 - outlet 1/2" FMPT
- Size 1.37" dia. hex 2.55" long

INSTALLATION

Observe the flow direction is into the male pipe thread end of the valve and out the female end. Use a suitable pipe thread sealant such as teflon tape. Avoid overtightening pipe threads. Normal torque applied with a 6 to 8 inch wrench is ample. Use ample Teflon tape - 3 or 4 turns, not one or two. The regulator is NOT shipped oxygen clean and should NOT be used for oxygen service as provided. Consult factory for details on oxygen service.

MAINTENANCE:

No routine maintenance is required. Should the valve become leaky seal replacement is required. In this case the valve can be disassembled and reassembled by qualified valve repair person following the drawing and notes herein. If time allows or a spare is available it is recommended the valve be returned to the factory for repairs. A repair kit consisting of seat, item 4 and poppet item 3 (part number 684-8) is available.

IN ALL CASES THE UNITS CAN BE RETURNED TO THE FACTORY OR DEALER FOR REPAIR AT A NOMINAL CHARGE.

PARTS LIST MODEL 684 CHECK VALVE

ITEM	QTY	PART NO.	DISC.
1	1	685	body
2	1	687	poppet retainer
3	1	686	poppet
4	1	684-4	seal 2-011, 90 duro viton
5	1	684-5	spring
6	1	684-6	retainer
7	1	684-7	label
8	1	684-8	repair kit (include items 3,4,5,6)

NOTES:

1. Technical bulletin - 598a
2. To assemble, install seal 4 on poppet 3. Install spring 5 on poppet 3. Drop poppet 3 into body 1. Install retainer 2 and retainer 6 using internal retainer ring pliers for 11/16" ring.

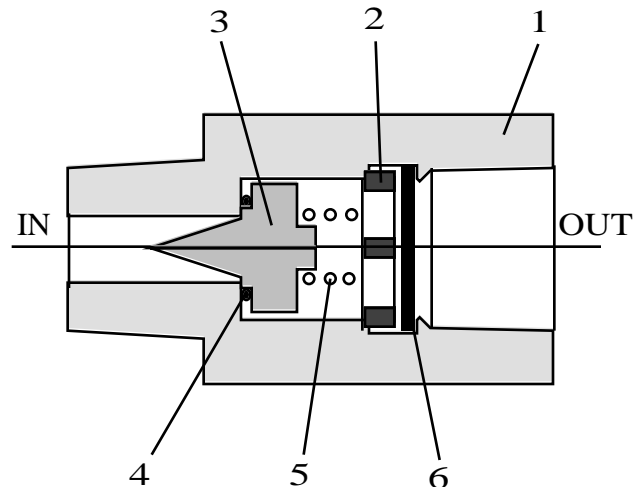

AQUA ENVIRONMENT CO. INC.,

3100 Kerner Blvd, Ste N, San Rafael, CA 94901, (415) 453 8157